

GW20060 Series

AC AXIAL FAN
 □ 202x202x61mm



Impeller : 5 blades,made of plastic PBT
 扇 叶: 5叶 PBT塑料

Frame : Made of die-cast aluminum ADC-12
 扇 框: 压铸铝 ADC-12

Motor : Capacitor-run induction motor
 電 機: 电容运转异步電機

Motor Protection : Thermally protection
 電機保护: 热保护



Model (型号)	Bearing System (轴承)	Rated Voltage (电压) [V]	Freq. (频率) [Hz]	Current (电流) [A]	Input power (功率) [W]	Speed (转速) [RPM]	Maximum Air Flow (风量) [CFM]	Maximum Air Flow (风量) [m³/min]	Max. Static Pressure (静压) [in-H2O]	Max. Static Pressure (静压) [Pa]	Niose Level (噪音) [dB-A]	Mass (质量) [g]
GW200601AH	Ball	115	50/60	0.63/0.72	72/80	2750/3100	460/530	13.0/15.0	0.45/0.51	112/127	60/65	1500
GW200602BH	Ball	230	50/60	0.32/0.36	72/80	2750/3100	460/530	13.0/15.0	0.45/0.51	112/127	60/65	1500
GW200603CH	Ball	380	50/60	0.19/0.20	72/80	2750/3100	460/530	13.0/15.0	0.45/0.51	112/127	60/65	1500
***GW200603LCH	Ball	3~380	50/60	0.19/0.20	72/80	2750/3100	460/530	13.0/15.0	0.45/0.51	112/127	60/65	1500

Dimensions Drawing

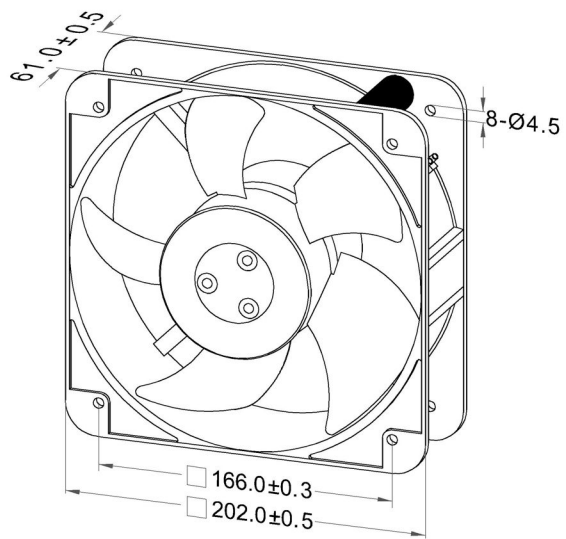

Air Flow & Static Pressure Curve

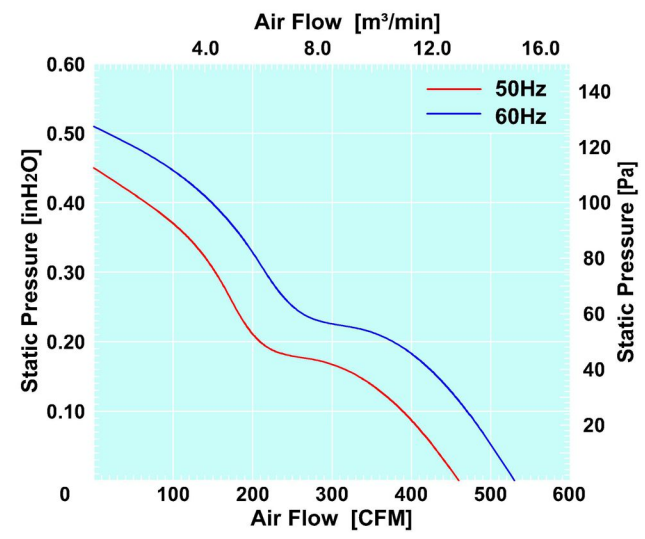

Above specification is only for reference and subject to change without notice.
 以上数据仅供参考，如有变更恕不另行通知。