

GW17251 Series EC AXIAL FAN

Ø 172x150x51 mm

- AUTO (RESTAR)
- PWM
- FG
- RD SIGNAL H
- RD SIGNAL L



Impeller : 7 blades, made of plastic PBT UL94 V-0
 扇 叶: 7叶, PBT塑料制, 阻燃等级UL94 V-0

Frame : Made of die-cas aluminum ADC-12
 扇 框: 压铸铝 ADC-12

Motor : 8 Poles brushless DC motor
 電 機: 8极无刷直流電機

Model (型号)	Bearing System (轴承)	Rated Voltage (电压) [VAC]	Voltage Range (电压范围) [VAC]	Freq. (频率) [Hz]	Input Power (功率) [W]	Speed (转速) [RPM]	Maximum Air Flow (风量) [CFM]	Maximum Air Flow (风量) [m³/min]	Max. Static Pressure (静压) [in-H ₂ O]	Max. Static Pressure (静压) [Pa]	Niose Level (噪音) [dB-A]	Mass (质量) [g]
GW1725111L	Ball	110	80~130	50/60	10.5	2000	187.4	5.31	0.28	69.7	51	643
GW1725122L	Ball	220	100~240	50/60	10.5	2000	187.4	5.31	0.28	69.7	51	643
GW1725111M	Ball	110	80~130	50/60	32	3000	280.1	7.93	0.47	117	59.5	648
GW1725122M	Ball	220	100~240	50/60	32	3000	280.1	7.93	0.47	117	59.5	648
GW1725111H	Ball	110	80~130	50/60	61.2	4000	348.3	9.86	1.16	288.8	66.8	652
GW1725122H	Ball	220	100~240	50/60	60	4000	348.3	9.86	1.16	288.8	66.8	652
GW1725111E	Ball	110	80~130	50/60	122	5000	451.8	12.8	1.7	423.3	73	655
GW1725122E	Ball	220	100~240	50/60	120	5000	451.8	12.8	1.7	423.3	73	655

Dimensions Drawing

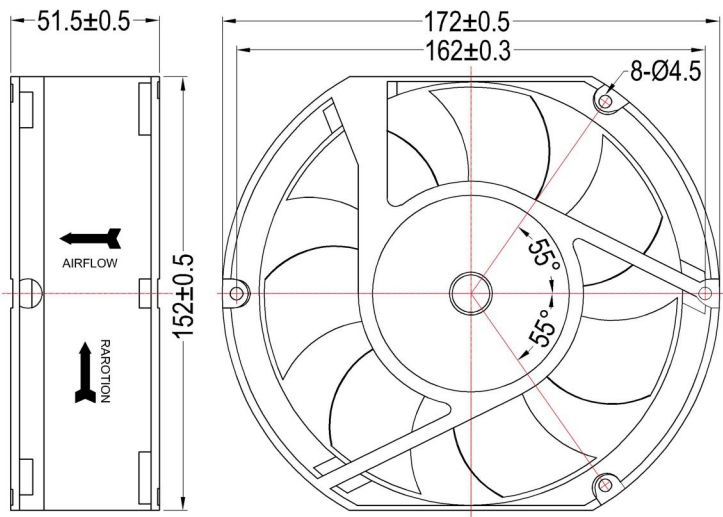

Air Flow & Static Pressure Curve

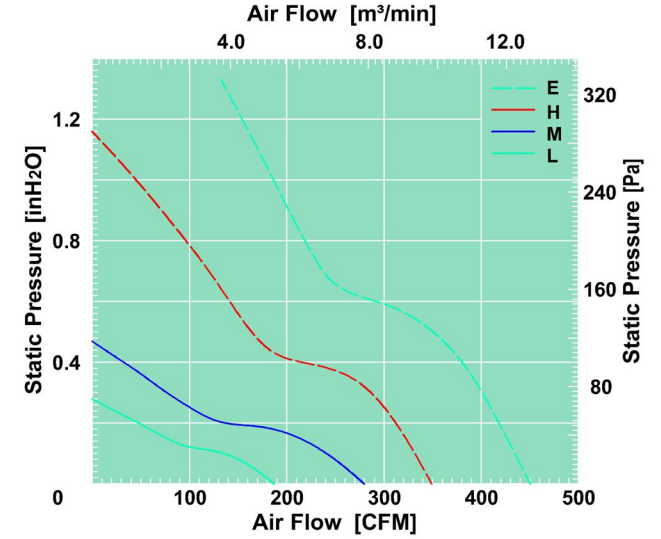

Above specification is only for reference and subject to change without notice.
 以上数据仅供参考, 如有变更恕不另行通知。