

**GW8025**  
[增压型]  
Series

**DC AXIAL FAN**  
□ 80 x 80 x 25 mm



Impeller : 9 blades, made of plastic PBT UL94 V-0

扇 叶: 9叶, PBT塑料制, 阻燃等级UL94 V-0

Frame : Made of plastic PBT UL94 V-0

扇 框: PBT塑料制, 阻燃等级UL94 V-0

Motor : 4 poles brushless DC motor

電 機: 4极无刷直流電機

Model (型号)	Bearing System (轴承)	Rated Voltage (电压) [V]	Voltage Range (电压范围) [V]	Current (电流) [A]	Speed (转速) [RPM]	Maximum Air Flow (风量) [CFM]	Maximum Air Flow (风量) [m³/min]	Max. Static Pressure (静压) [inH2O]	Max. Static Pressure (静压) [Pa]	Niose Level (噪音) [dB-A]	Mass (质量) [g]
GW802512L	B/S	12	6.0~13.5	0.34	4000	54.4	1.54	0.36	89.4	44	78
GW802524L	B/S	24	18.0~26.5	0.17	4000	54.4	1.54	0.36	89.4	44	78
GW802548L	B/S	48	36.0~54.0	0.10	4000	54.4	1.54	0.36	89.4	44	78
GW802512M	B/S	12	6.0~13.5	0.50	4500	61.0	1.72	0.45	112	48	80
GW802524M	B/S	24	18.0~26.5	0.25	4500	61.0	1.72	0.45	112	48	80
GW802548M	B/S	48	36.0~54.0	0.13	4500	61.0	1.72	0.45	112	48	80
GW802512H	B/S	12	6.0~13.5	0.72	5000	70.6	2.0	0.55	137	50	82
GW802524H	B/S	24	18.0~26.5	0.36	5000	70.6	2.0	0.55	137	50	82
GW802548H	B/S	48	36.0~54.0	0.20	5000	70.6	2.0	0.55	137	50	82

**Dimensions Drawing**

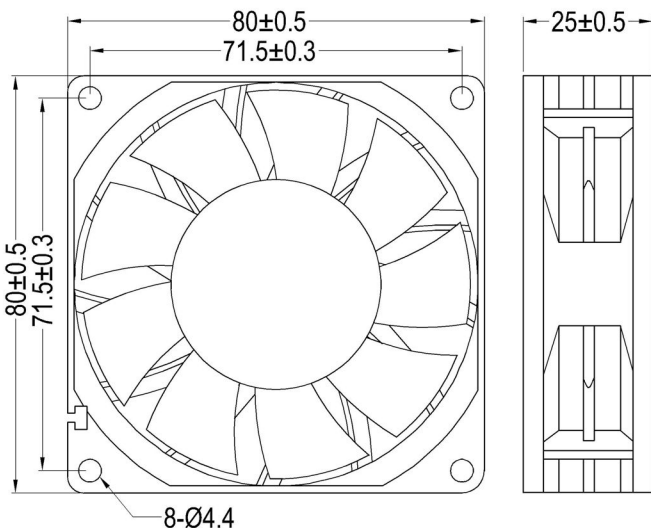

**Air Flow & Static Pressure Curve**

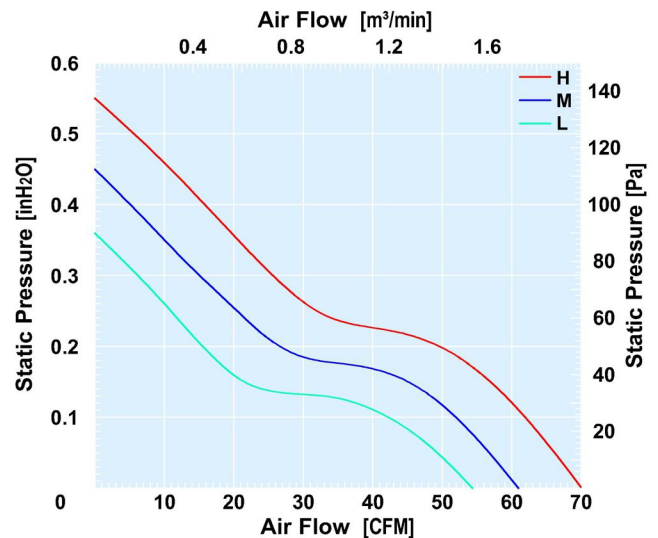

Above specification is only for reference and subject to change without notice.  
以上数据仅供参考, 如有变更恕不另行通知。