



AIR SPACE

直流軸流風扇

www.pudaelec.com

GW5015 Series DC AXIAL FAN

□ 50 x 50 x 15 mm

- AUTO (RESTAR)
- PWM
- FG
- RD SIGNAL H
- RD SIGNAL L



Impeller : 7 blades,made of plastic PBT UL94 V-0

扇 叶: 7叶, PBT塑料制, 阻燃等级UL94 V-0

Frame : Made of plastic PBT UL94 V-0

扇 框: PBT塑料制, 阻燃等级UL94 V-0

Motor : 4 poles brushless DC motor

電 機: 4极无刷直流電機

Model (型号)	Bearing System (轴承)	Rated Voltage (电压) [V]	Voltage Range (电压范围) [V]	Current (电流) [A]	Speed (转速) [RPM]	Maximum Air Flow (风量) [CFM]	Maximum Air Flow (风量) [m³/min]	Max. Static Pressure (静压) [inH ₂ O]	Max. Static Pressure (静压) [Pa]	Niose Level (噪音) [dB-A]	Mass (质量) [g]
GW501505L	B/S	5	3.6~6.8	0.16	4200	9.18	0.26	0.15	37.35	27	26
GW501512L	B/S	12	6.0~13.5	0.10	4200	9.18	0.26	0.15	37.35	27	26
GW501524L	B/S	24	18.0~26.5	0.05	4200	9.18	0.26	0.15	37.35	27	26
GW501505M	B/S	5	3.6~6.8	0.21	5300	11.11	0.31	0.21	52.3	32	26
GW501512M	B/S	12	6.0~13.5	0.12	5300	11.11	0.31	0.21	52.3	32	26
GW501524M	B/S	24	18.0~26.5	0.08	5300	11.11	0.31	0.21	52.3	32	26
GW501512H	B/S	12	6.0~13.5	0.21	6400	14.66	0.41	0.27	67.2	35	26.5
GW501524H	B/S	24	18.0~26.5	0.10	6400	14.66	0.41	0.27	67.2	35	26.5
GW501512E	B/S	12	6.0~13.5	0.26	7500	17.20	0.49	0.37	92.1	38	26.5
GW501524E	B/S	24	18.0~26.5	0.15	7500	17.20	0.49	0.37	92.1	38	26.5

Dimensions Drawing

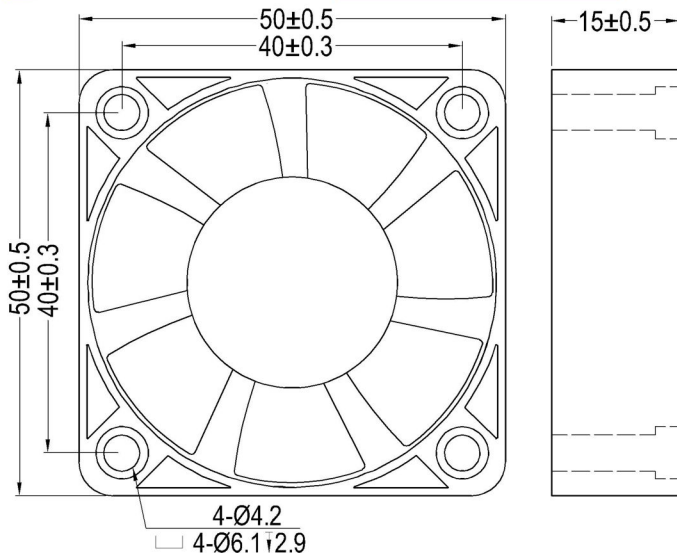

Above specification is only for reference and subject to change without notice.

以上数据仅供参考, 如有变更恕不另行通知。

Air Flow & Static Pressure Curve

