



# GW4015 Series DC AXIAL FAN

□ 40 x 40 x 15 mm

- AUTO (RESTAR)
- PWM
- FG
- RD SIGNAL H
- RD SIGNAL L



Impeller : 7 blades ,made of plastic PBT UL94 V-0

扇 叶: 7叶, PBT塑料制, 阻燃等级UL94 V-0

Frame : Made of plastic PBT UL94 V-0

扇 框: PBT塑料制, 阻燃等级UL94 V-0

Motor : 4 poles brushless DC motor

電 機: 4极无刷直流電機

Model (型号)	Bearing System (轴承)	Rated Voltage (电压) [V]	Voltage Range (电压范围) [V]	Current (电流) [A]	Speed (转速) [RPM]	Maximum Air Flow (风量) [CFM]	Maximum Air Flow (风量) [m³/min]	Max. Static Pressure (静压) [inH <sub>2</sub> O]	Max. Static Pressure (静压) [Pa]	Niose Level (噪音) [dB-A]	Mass (质量) [g]
GW401505L	B/S	5	3.6~6.8	0.12	4000	5.8	0.164	0.132	32.9	18.9	22
GW401512L	B/S	12	6.0~13.5	0.05	4000	5.8	0.164	0.132	32.9	18.9	22
GW401524L	B/S	24	18.0~26.5	0.04	4000	5.8	0.164	0.132	32.9	18.9	22
GW401505M	B/S	5	3.6~6.8	0.21	6000	8.13	0.230	0.202	50.3	25.3	23
GW401512M	B/S	12	6.0~13.5	0.10	6000	8.13	0.230	0.202	50.3	25.3	23
GW401524M	B/S	24	18.0~26.5	0.08	6000	8.13	0.230	0.202	50.3	25.3	23
GW401512H	B/S	12	6.0~13.5	0.14	8000	11.36	0.321	0.355	88.4	32.6	24
GW401524H	B/S	24	18.0~26.5	0.10	8000	11.36	0.321	0.355	88.4	32.6	24
GW401512E	B/S	12	6.0~13.5	0.19	10000	13.6	0.385	0.484	120.5	39.6	24.5
GW401524E	B/S	24	18.0~26.5	0.12	10000	13.6	0.385	0.484	120.5	39.6	24.5

### Dimensions Drawing

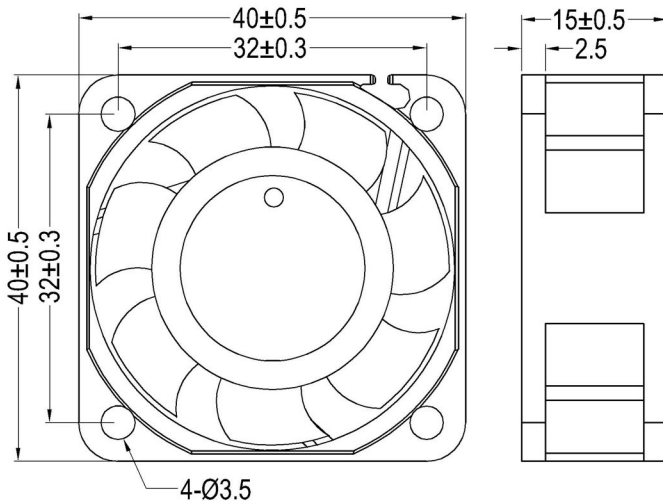

### Air Flow & Static Pressure Curve

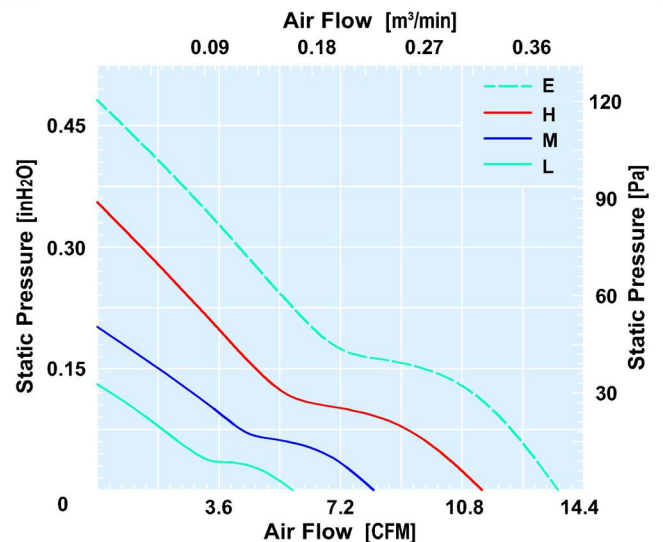

Above specification is only for reference and subject to change without notice.  
以上数据仅供参考, 如有变更恕不另行通知。